

CHAKSHUYAAN 40 SERIES

v 1.0
2026.03

Maintenance Manual

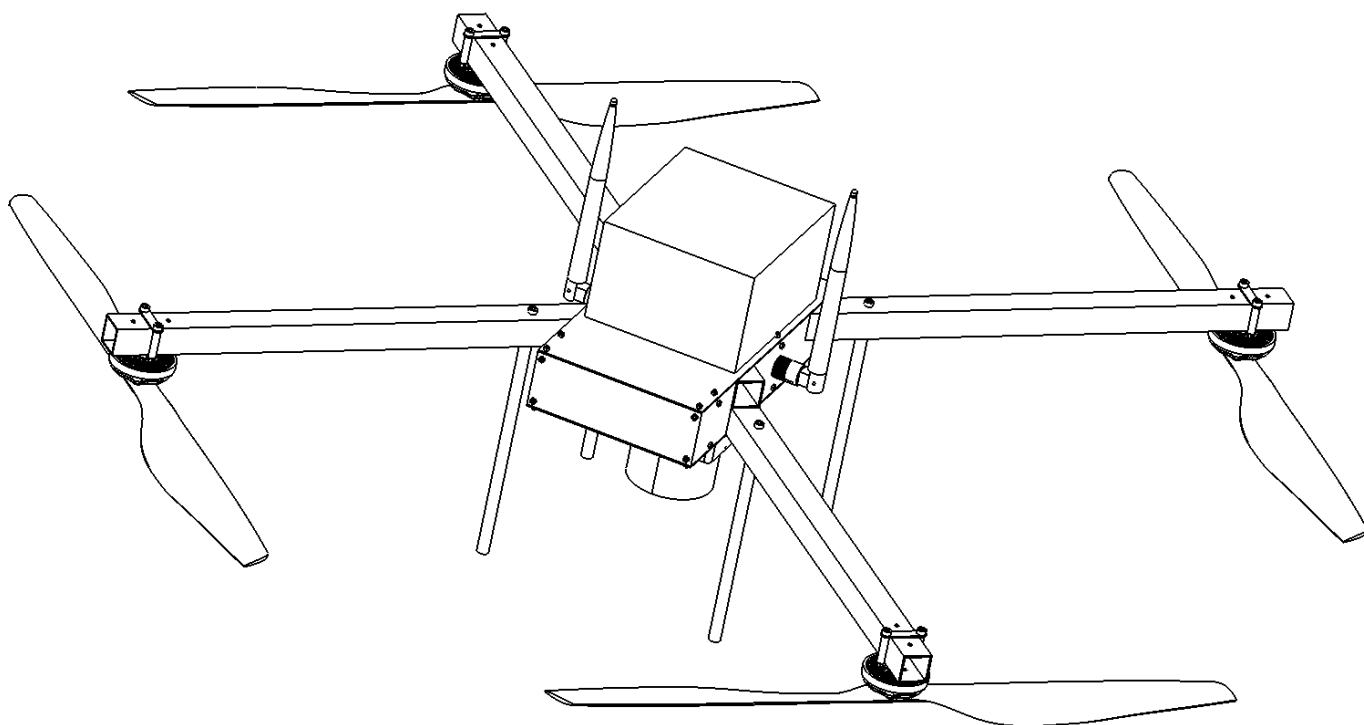



This document and the information contained herein are the exclusive property of **IndiFlo Technologies Pvt. Ltd.** (“IndiFlo”) and are protected under applicable copyright laws and international intellectual property treaties. All rights are strictly reserved.

No part of this document may be reproduced, duplicated, distributed, transmitted, disclosed, translated, stored in a retrieval system, or utilized in any form or by any means—electronic, mechanical, photocopying, recording, or otherwise—without the prior written authorization of IndiFlo.

This document is furnished solely for the purpose of supporting the authorized operation, installation, integration, maintenance, and servicing of IndiFlo Unmanned Aerial Vehicle (UAV) systems. It shall not be used for any other purpose, including but not limited to reverse engineering, product benchmarking, competitive analysis, or derivative development.

The technical data contained herein is subject to change without notice. IndiFlo assumes no responsibility for typographical errors, omissions, or for damages resulting from the use or misuse of the information provided.

Possession of this document does not convey any license, express or implied, under any IndiFlo patent, trademark, trade secret, or other proprietary right.

Unauthorized use or disclosure may result in civil and/or criminal liability under applicable law.



CONTENT

Introduction	1
Regulatory compliance	2
Safety information and classification	3
Disclaimer	4
Safety flight guidelines	5
Storage and transportation	7
Firmware and software management	8
Inspection and management	9
Regular maintenance	13
Aircraft structure	16
Battery system	21
Battery maintenance	22
Standard charge and discharge maintenance procedure	23
Battery replacement criteria	24
Storage conditions	24
Battery disposal procedure	25
List of wearing parts	26
Performance parameters	27
UAS Component description	28
UAS set-up procedure	32
GCS setup	34
UAV features	36
Caliberation procedure	38
Operating procedure	41
Operating limitation	42
Flight mission planning	43
Emergency procedure	44
Warranty clause	48
Warranty exclusion	51



INTRODUCTION

Purpose

This Maintenance Manual provides mandatory procedures, inspection criteria, servicing instructions, and continued airworthiness guidance for IndiFlo Unmanned Aerial Vehicle (UAV) systems.

The objective of this document is to ensure safe operation, regulatory compliance, structural integrity, and system reliability throughout the operational life cycle of the aircraft.

This manual forms part of the approved technical documentation set and shall be used only by trained, qualified, and authorized personnel.

Applicable Documents

This manual shall be read in conjunction with, but not limited to, the following IndiFlo publications:

1. User Manual
2. Installation Manual
3. Wiring & Integration Manual
4. Service Bulletins (SB)
5. Technical Notes (TN)
6. Continued Airworthiness Instructions (ICA)
7. Approved Configuration & Revision Record

Only the latest released revision of each document shall be considered valid.



REGULATORY COMPLIANCE

Compliance Responsibility

Operation and maintenance of IndiFlo UAV systems shall be conducted in accordance with:

1. Applicable national civil aviation regulations Local airspace restrictions and operational category approvals
2. Maintenance and inspection requirements defined by the competent authority

The operator is solely responsible for ensuring compliance with all applicable aviation regulations, airworthiness directives, operational limitations, and certification requirements within their jurisdiction.

IndiFlo provides technical documentation to support compliance; however, regulatory approval, operational authorization, and mission legality remain the responsibility of the operator.

Continued Airworthiness

To maintain airworthiness:

1. Scheduled inspections must be performed at defined intervals and within prescribed timelines.
2. Only authorized modifications, approved spare parts must be used and authorized personnel shall perform maintenance procedures.

Failure to comply with prescribed maintenance actions may invalidate warranty, certification status, or regulatory approval.



SAFETY INFORMATION AND CLASSIFICATION

Safety Definitions

This manual uses standardized safety classifications consistent with aerospace and defense documentation practices.

DANGER

Indicates a hazardous situation which, if not avoided, **will result in death or serious injury**.

WARNING

Indicates a hazardous situation which, if not avoided, **could result in death or serious injury**.

CAUTION

Indicates a hazardous situation which, if not avoided, **may result in minor or moderate injury**, equipment damage, or degradation of system performance.

NOTICE

Indicates important information related to operational procedures, reliability, or best practices, but not related to personal injury.



DISCLAIMER

Prior to installation, operation, or maintenance, users must fully read and understand this manual and all associated technical publications.

By operating or servicing this product, the user acknowledges and agrees that:

1. They assume full responsibility for safe and lawful operation.
2. They will comply with all applicable aviation regulations.
3. They understand the inherent risks associated with UAV operations.

IndiFlo Technologies Pvt. Ltd. shall not be liable for:

1. Damage resulting from misuse, negligence, or unauthorized modification
2. Failure to follow maintenance procedures
3. Improper installation or integration
4. Non-compliance with regulatory requirements

IndiFlo reserves the right to revise specifications, procedures, and documentation without prior notice.



SAFETY FLIGHT GUIDELINES

Flight Condition Requirements

Operational Requirements

Prior to each flight, the operator shall:

1. Read and understand the Disclaimer, Safety Guidelines, User Manual, and Maintenance Manual.
2. Verify aircraft configuration and airworthiness status.
3. Confirm that all required inspections have been completed and documented.
4. Ensure firmware versions and configuration parameters are current and approved.
5. Verify that environmental and operational conditions fall within specified limitations.

Operation of the aircraft without completing the above requirements may result in unsafe conditions, regulatory violations, or loss of aircraft control.



Flight Restrictions

Airspace Compliance

The operator shall:

1. Ensure the aircraft navigation database, geofencing data, and airspace restriction information are updated prior to flight.
2. Verify compliance with applicable civil aviation authority regulations (e.g., DGCA, FAA, EASA, or other local authority requirements).
3. Confirm that the intended flight area is authorized for UAV operations.
4. Obtain all necessary flight permissions, waivers, or NOTAM clearances where required.

Failure to comply with regulated airspace restrictions may result in civil penalties, criminal liability, or revocation of operating privileges.

Restricted or Controlled Zones

If flight within controlled, restricted, or geofenced zones is required:

1. Apply for authorization through the appropriate aviation authority.
2. Obtain documented approval prior to arming the aircraft.
3. Ensure unlocking or geofence override procedures (if applicable) are completed in accordance with IndiFlo authorization protocols.

Unauthorized operation in restricted airspace is strictly prohibited.



STORAGE AND TRANSPORTATION

General Requirements

Storage and transportation of IndiFlo UAV systems and Intelligent Flight Batteries shall comply with applicable safety standards and hazardous material regulations.

The operator shall:

1. Store aircraft in a clean, dry, temperature-controlled environment.
2. Protect sensitive components from moisture, dust, vibration, and electrostatic discharge.
3. Use approved packaging during transportation.

Battery Safety

Intelligent Flight Batteries shall:

1. Be stored within specified temperature and humidity limits.
2. Be transported in compliance with UN transportation regulations for lithium-based batteries.
3. Be inspected for swelling, leakage, or physical damage prior to use.

Damaged batteries shall be removed from service immediately.



FIRMWARE AND SOFTWARE MANAGEMENT

Firmware Update Requirements (if applicable)

To maintain system integrity and performance:

1. Aircraft firmware, flight controller firmware, payload firmware, and remote controller firmware shall be maintained at approved release versions.
2. Updates shall be performed only using official IndiFlo software tools.
3. Firmware revisions shall be documented in maintenance records.

Update Failure Protocol

If a firmware update fails:

1. Power cycle the device and reattempt the update.
2. Verify stable power supply and communication integrity.
3. If the issue persists, contact IndiFlo Authorized Technical Support.

Operation with incomplete or corrupted firmware is prohibited.



INSPECTION AND MAINTENANCE

Routine inspection prior to each operation and scheduled maintenance at defined intervals are mandatory to ensure continued airworthiness, operational safety, and system reliability.

1. Proper inspection and preventive maintenance:
2. Reduce the probability of in-flight failures
3. Mitigate operational safety hazards
4. Maintain system performance and accuracy
5. Extend structural and electronic component service life

Failure to conduct required inspections may result in equipment malfunction, loss of aircraft control, or invalidation of warranty and regulatory compliance status.



Pre-Flight Checklist

The following Pre-Flight Checklist shall be completed prior to each flight. This checklist serves as the minimum required inspection for daily operations.

Power System

1. Verify that aircraft batteries and remote controller batteries are fully charged or within approved operational limits.
2. Confirm that all batteries are securely installed and locking mechanisms are fully engaged.
3. Inspect batteries for swelling, leakage, physical damage, or abnormal heating. Do not operate if defects are observed.

Propulsion System

1. Verify that all propellers are securely mounted and properly torqued.
2. Inspect propellers for cracks, deformation, chipping, or imbalance. Replace if necessary.
3. Ensure motors are free of foreign objects, debris, or obstruction.
4. Confirm all folding arms (if applicable) are fully extended and locked in position.



Airframe and Structural Integrity

1. Inspect the airframe for cracks, loose fasteners, structural deformation, or abnormal wear.
2. Verify that landing gear is secure and free of damage.
3. Confirm that access covers, data ports, payload interfaces, and storage compartments are properly closed and secured.

Avionics and Sensors

1. Clean and inspect camera lenses, FPV systems, navigation sensors, and obstacle detection sensors.
2. Ensure no protective films, dust, or obstructions are present.
3. Confirm the gimbal is unlocked and free to move without restriction.
4. Verify payload mounting integrity (if applicable).

Communication and Control

1. Adjust remote controller antennas to the recommended orientation.
2. Power on the remote controller and aircraft in accordance with startup procedure.
3. Confirm successful link between aircraft and controller.
4. Verify telemetry data, GPS lock status, and navigation mode.
5. Ensure status indicators display normal operational condition.



Flight Environment Verification

1. Place the aircraft on stable, flat, and unobstructed ground.
2. Ensure adequate clearance from personnel, structures, power lines, and vegetation.
3. Maintain a minimum safe distance between aircraft and pilot as specified in operational limitations.
4. Confirm wind speed, temperature, and environmental conditions are within approved operating limits.

System Configuration and Failsafe Settings

1. Verify flight mode configuration.
2. Confirm Return-To-Home (RTH) altitude is set appropriately for the operational environment.
3. Verify failsafe behavior for loss of signal and low battery conditions.
4. Confirm obstacle avoidance parameters are enabled or configured as required for the mission (if applicable).

Multi-Aircraft Operations (If Applicable)

1. Establish airspace deconfliction procedures prior to simultaneous operations.
2. Assign altitude separation or defined operational zones to prevent mid-air collision risk.
3. Confirm communication protocol among operators.
4. Completion of this checklist shall be documented in accordance with operator record-keeping procedures where required by regulation or internal quality systems.



REGULAR MAINTENANCE

Regular maintenance shall be performed at defined intervals to ensure continued airworthiness, structural integrity, propulsion reliability, and system performance.

Maintenance shall be carried out by qualified personnel in accordance with this manual and applicable regulatory requirements.

TYPE	MAINTENANCE ITEM	PERIOD
Basic maintenance	<ol style="list-style-type: none"> 1. General inspection 2. Deep cleaning of airframe and components 3. Firmware verification and updates 4. System diagnostics 5. Sensor calibration 	According to user's requirement
Routine maintenance	<p>All Basic Maintenance tasks and</p> <ol style="list-style-type: none"> 1. Detailed structural inspection 2. Fastener torque verification 3. Propulsion system inspection 4. Replacement of wear-and-tear components 5. Functional testing of avionics and communication systems 	500 hours/1 year, whichever is earlier
Major maintenance	<p>All Routine Maintenance tasks and</p> <ol style="list-style-type: none"> 1. Comprehensive propulsion system inspection 2. Motor performance validation 3. Power distribution system inspection 4. Replacement of time-life limited components 5. Structural fatigue evaluation 	800 hours/18 months, whichever is earlier



REGULAR MAINTENANCE ITEMS

TYPE	INSPECTION PROCEDURE	REJECTION CRITERIA
Motor rotation inspection	<ol style="list-style-type: none"> 1. Unfold and secure all frame arms (if applicable). 2. Manually rotate each motor rotor. 3. Verify smooth and uniform rotation without abnormal resistance. 4. Observe the clearance between rotor and stator to confirm no mechanical contact. 5. Inspect for: <ul style="list-style-type: none"> ▪ Foreign object debris (FOD) ▪ Scraping, grinding, or rubbing noise ▪ Excessive axial or radial play 6. Repeat for all motors. 	<ol style="list-style-type: none"> 1. Motor rotation is obstructed. 2. Rotor-to-stator contact is observed. 3. Abnormal friction or grinding is present. 4. Mechanical damage or deformation is detected.
Motor-to-Arm Structural Connection	<ol style="list-style-type: none"> 1. Rotate the motor base gently around the central carbon tube axis to verify that no looseness exists. 2. Inspect motor mounting interface for movement relative to the arm structure. 3. Verify that all motor mounting screws are present and properly torqued. 4. Inspect for cracks, delamination, or structural damage in the arm material. 	<ol style="list-style-type: none"> 1. Any detectable looseness between motor and arm. 2. Missing or loose mounting screws. 3. Structural cracks or material fatigue.



REGULAR MAINTENANCE ITEMS

TYPE	INSPECTION PROCEDURE	REJECTION CRITERIA
Propeller	<ol style="list-style-type: none"> 1. Inspect each propeller for: 2. Visible deformation 3. Surface cracks 4. Severe wear 5. Nicks or edge damage 6. Delamination (if composite) 7. Check for foreign material adhered to blades. 8. Clean propellers using a dry, lint-free cloth. 9. Verify secure attachment to motor hub. 	<ol style="list-style-type: none"> 1. Motor rotation is obstructed. 2. Rotor-to-stator contact is observed. 3. Abnormal friction or grinding is present. 4. Mechanical damage or deformation is detected.
Propeller Adapter and Mounting Hardware	<ol style="list-style-type: none"> 1. Verify propeller adapter screws are present and properly torqued. 2. Inspect for looseness or abnormal play. 3. Inspect threads for wear or stripping. 4. Apply approved thread-locking compound if reinstallation is required. 	<ol style="list-style-type: none"> 1. Loose adapter assembly. 2. Damaged threads. 3. Deformed mounting surfaces.



AIRCRAFT STRUCTURE

General Inspection Requirements

Structural inspections shall be conducted during pre-flight checks and at scheduled maintenance intervals to ensure structural integrity, mechanical security, and environmental protection of the aircraft.

TYPE	INSPECTION PROCEDURE	REJECTION CRITERIA
Aircraft Appearance	<ol style="list-style-type: none"> 1. Inspect the aircraft exterior for visible cracks, deformation, impact marks, corrosion, or structural damage. 2. Ensure all external surfaces are clean and free from oil, dust, or residue. 3. Clean the airframe using a soft, lint-free cloth. 4. Pay particular attention to: <ul style="list-style-type: none"> • Infrared sensing lenses • Vision system cameras • Auxiliary lights and beacons • Heat dissipation vents 	<ol style="list-style-type: none"> 1. Structural cracks or material delamination. 2. Loose panels or exposed internal components. 3. Contamination obstructing sensors or cooling airflow of the motors.
Fasteners and Screws	<ol style="list-style-type: none"> 1. Verify that all visible screws and fasteners are present and properly seated. 2. Inspect for signs of loosening, corrosion, or stripped threads. 3. Pay special attention to: <ul style="list-style-type: none"> • Motor-to-arm connection screws • Carbon tube structural fasteners • Payload mounting screws 	<ol style="list-style-type: none"> 1. Missing hardware. 2. Loose fasteners. 3. Evidence of thread damage or structural movement.



AIRCRAFT STRUCTURE

TYPE	INSPECTION PROCEDURE	REJECTION CRITERIA
Frame Arms	<ol style="list-style-type: none"> 1. Verify that all arm mounting screws (9 total) are secure. 2. Rotate each frame arm to confirm smooth movement without excessive play. 3. Inspect arm joints for cracks, deformation, or material fatigue. 4. Verify that screw nuts attached to shaft screws remain secure during rotation. 	<ol style="list-style-type: none"> 1. Cracked arm joints. 2. Excessive lateral play. 3. Failure of folding mechanism to lock securely. 4. Abnormal stiffness or grinding during rotation.
Propeller Adapter and Mounting Hardware	<ol style="list-style-type: none"> 1. Verify propeller adapter screws are present and properly torqued. 2. Inspect for looseness or abnormal play. 3. Inspect threads for wear or stripping. 4. Apply approved thread-locking compound if reinstallation is required. 	<ol style="list-style-type: none"> 1. Loose adapter assembly. 2. Damaged threads. 3. Deformed mounting surfaces.
Frame Arm LEDs	<ol style="list-style-type: none"> 1. Inspect LED housings for cracks, moisture ingress, or contamination. 2. Verify no foreign objects or impact damage are present. 3. Confirm LED indicators function during system power-on check. 	<ol style="list-style-type: none"> 1. Cracked housing. 2. Non-functional status indicators. 3. Moisture inside LED assembly.



AIRCRAFT STRUCTURE

TYPE	INSPECTION PROCEDURE	REJECTION CRITERIA
Battery Compartment	<ol style="list-style-type: none"> 1. Inspect battery ports for cleanliness, dryness, and absence of corrosion. 2. Remove dust or moisture if present. 3. After battery installation, verify locking mechanism engages securely without abnormal movement. 	<ol style="list-style-type: none"> 1. Corroded or contaminated power contacts. 2. Loose release mechanism. 3. Incomplete locking/strapping engagement. 4. Excessive vibration or movement of installed battery.
Data Ports	<ol style="list-style-type: none"> 1. Clean residue near ports using lint-free gauze. 2. Disconnect cables prior to inspection. 3. Inspect port interior using appropriate lighting. 4. Remove foreign objects using non-conductive tools (e.g., tweezers). 5. Clean dust or fine debris by gently brushing away from port opening. 	<ol style="list-style-type: none"> 1. Bent pins or connector damage. 2. Embedded foreign objects. 3. Signs of electrical corrosion.
microSD Card Slot	<ol style="list-style-type: none"> 1. Verify no foreign objects are present in the slot. 2. Confirm card is properly seated and locked. 3. Perform functional check via system interface. 4. Inspect card contacts for contamination. 	<ol style="list-style-type: none"> 1. Damaged slot mechanism. 2. Improper seating. 3. Data read/write malfunction.



AIRCRAFT STRUCTURE

TYPE	INSPECTION PROCEDURE	REJECTION CRITERIA
Rubber Port Covers	<ol style="list-style-type: none"> 1. Inspect battery ports for cleanliness, dryness, and absence of corrosion. 2. Remove dust or moisture if present. 3. After battery installation, verify locking mechanism engages securely without abnormal movement. 	<ol style="list-style-type: none"> 1. Corroded or contaminated power contacts. 2. Loose release mechanism. 3. Incomplete locking/strapping engagement. 4. Excessive vibration or movement of installed battery.
Data Ports	<ol style="list-style-type: none"> 1. Clean residue near ports using lint-free gauze. 2. Disconnect cables prior to inspection. 3. Inspect port interior using appropriate lighting. 4. Remove foreign objects using non-conductive tools (e.g., tweezers). 5. Clean dust or fine debris by gently brushing away from port opening. 	<ol style="list-style-type: none"> 1. Bent pins or connector damage. 2. Embedded foreign objects. 3. Signs of electrical corrosion.
microSD Card Slot	<ol style="list-style-type: none"> 1. Verify no foreign objects are present in the slot. 2. Confirm card is properly seated and locked. 3. Perform functional check via system interface. 4. Inspect card contacts for contamination. 	<ol style="list-style-type: none"> 1. Damaged slot mechanism. 2. Improper seating. 3. Data read/write malfunction.



AIRCRAFT STRUCTURE

TYPE	INSPECTION PROCEDURE	REJECTION CRITERIA
Gimbal Damping Plate (if applicable)	<ol style="list-style-type: none"> 1. Verify mounting screws between damping plate and aircraft body are secure. 2. Inspect for abnormal gimbal oscillation. 3. Inspect vibration dampeners for: <ul style="list-style-type: none"> • Cracking • Hardening • Looseness • Aging 	<ol style="list-style-type: none"> 1. Damaged dampeners. 2. Loose mounting interface. 3. Excessive vibration during system check.
Gimbal Camera Assembly (if applicable)	<ol style="list-style-type: none"> 1. Rotate gimbal pitch axis to +90° (transport position) if required. 2. Inspect camera housing for structural damage. 3. Inspect lenses for scratches, cracks, or contamination. 4. Verify smooth gimbal motion during initialization. 	<ol style="list-style-type: none"> 1. Cracked optics. 2. Binding or restricted motion. 3. Loose camera housing.
Infrared Sensing and Vision System Lenses, Auxiliary Lights, and Beacons (if applicable)	<ol style="list-style-type: none"> 1. Clean all sensor lenses using soft optical cloth. 2. Verify lenses are secure and free of cracks. 3. Confirm functional illumination during power-on test 4. Inspect auxiliary lights and beacons for: <ul style="list-style-type: none"> • Looseness • Cracking • Moisture ingress 	<ol style="list-style-type: none"> 1. Sensor misalignment. 2. Cracked or loose optical assemblies. 3. Non-functional auxiliary lighting.



BATTERY SYSTEM

Battery Configuration

The IndiFlo Intelligent Flight Battery consists of:

1. **Cell Configuration:** 6S5P (6 cells in series, 5 cells in parallel)
2. **Cell Type:** Molicel INR-21700-M65A lithium-ion cells
3. **Nominal Voltage (Pack):** 21.6 V
4. **Maximum Charge Voltage:** 25.2 V
5. **Cell Nominal Voltage:** 3.6 V
6. **Maximum Cell Voltage:** 3.70 V

Minimum Recommended Cell Voltage: 3.0 V (under load)

The battery pack incorporates an integrated Battery Management System (BMS) providing:

1. Cell balancing
2. Over-voltage protection
3. Under-voltage protection
4. Over-current protection
5. Over-temperature protection
6. Short-circuit protection



BATTERY MAINTENANCE

Battery maintenance shall be performed when any of the following conditions occur:

1. Every **50 charge-discharge cycles**.
2. The battery remains unused for more than **three (3) months**.
3. A battery maintenance prompt appears in the IndiFlo control application.
4. Cell voltage deviation exceeds specified tolerance.

Failure to conduct required maintenance may result in capacity degradation, imbalance, or premature cell aging.

BATTERY MAINTENANCE CHECKLIST

The following inspection shall be conducted:

1. Perform controlled charge and discharge cycle
2. Install battery in aircraft and power ON.
3. Verify via system interface:
 - Cell voltage difference is $\leq 0.10 \text{ V}$
 - Firmware is updated to approved revision
 - No BMS fault codes are present
4. Inspect battery housing for:
 - Swelling
 - Leakage
 - Cracking
 - Impact damage

Inspect power terminals for corrosion or contamination.
Confirm battery locking mechanism operates correctly.



STANDARD CHARGE AND DISCHARGE MAINTENANCE PROCEDURE

This procedure is required to maintain cell balance and capacity calibration.

Step 1 – Full Charge

1. Charge battery to **100% (25.2 V pack voltage)** using approved IndiFlo charger.
2. Allow battery to rest for **24 hours** at ambient temperature (20–25°C).

Step 2 – Controlled Discharge

1. Install battery into aircraft.
2. Conduct flight operation or controlled discharge.
3. Land aircraft when battery reaches **$\leq 20\%$ state of charge**.
4. Remove battery from aircraft.

Step 3 – Rest Period

1. Allow battery to rest for **1 hour** at room temperature.

Step 4 – Recharge

1. Recharge battery fully to 100%, or
2. Charge to **storage level (40–60% SOC)** if long-term storage is intended.



BATTERY REPLACEMENT CRITERIA

1. Battery shall be permanently removed from service if:
2. Visible swelling, leakage, or mechanical damage is observed.
3. Cell voltage imbalance exceeds **0.15 V after balancing cycle**.
4. Internal resistance deviation exceeds manufacturer specification.
5. The battery has completed **400 full equivalent cycles**.
6. BMS fault persists after two consecutive maintenance cycles.
7. Capacity degradation exceeds **20% of rated capacity**.
8. Continued use beyond rated life may result in thermal risk or reduced flight safety.

STORAGE CONDITIONS

1. For storage longer than 7 days:
2. Maintain charge level at **40–60% SOC**.
3. Store at **15°C to 25°C**, relative humidity < 65%.
4. Avoid direct sunlight and high-temperature environments.
5. Do not store fully charged or fully discharged.
6. Storage beyond 3 months requires maintenance cycle prior to reuse.



BATTERY DISPOSAL PROCEDURE

WARNING: Lithium-ion batteries pose fire and chemical hazards if improperly handled.

For decommissioned batteries:

1. Discharge battery to \leq **5% SOC** using controlled load.
2. Remove protective labeling as required by disposal regulations.
3. Submerge battery in **5% saltwater solution** in a non-metallic insulated container.
4. Leave immersed for **minimum 48 hours** to ensure full discharge.
5. Dispose of battery in accordance with local hazardous material regulations (UN 3480 – Lithium-ion batteries).

Do not incinerate or puncture battery pack.



LIST OF WEARING PARTS

Replace parts that are easily damaged and worn by due course of time under regular usage for best flight performance and reduce safety hazard

No	Categories	Quantity
1	CW propeller blade	2
2	CCW propeller blade	2
3	CW motors	2
4	CCW motors	2
5	Landing gears	4



PERFORMANCE PARAMETERS

Number	Parameter	Value
1	Minimum Operating Speed	0 m/s
2	Maximum Operating Speed	12 m/s
3	Maximum Range	
4	Maximum Endurance	85 mins
5	Operational Altitude	400 feet
6	Ceiling Height	
7	Speed of Climb	
8	Speed of Descent	
9	Operational Envelope of UAS	
10	IP Rating of the Drone	
11	HIRF Susceptibility	
12	Geofencing Capability	
13	SSR Transponder	
14	GNSS	



UAS COMPONENT DESCRIPTION

This section provides a technical overview of major Unmanned Aircraft System (UAS) components, including propulsion elements, ground control architecture, energy storage system, and mission payloads.

All components listed herein are approved for integration within the certified IndiFlo platform configuration unless otherwise stated.

1. Propeller system

General Description

The aircraft is equipped with **T-Motor 20-inch NS Series propellers**, designed for high-efficiency multirotor propulsion applications.

Diameter: 20 inches

Pitch: 6.1 inches

Propeller Type: Two-blade composite

Mounting Interface: Standard hub adapter (as specified in propulsion assembly)

Rotation: Clockwise (CW) and Counter-Clockwise (CCW) configuration



2. Ground Control Station (GCS)

System Overview

The IndiFlo Ground Control Station (GCS) is a repackaged and customized implementation based on the PX4 open-source flight control ecosystem.

Functional Capabilities

1. Real-time telemetry monitoring
2. Flight mode selection and control
3. Geofence configuration
4. Return-To-Home (RTH) configuration
5. Failsafe parameter configuration
6. Payload trigger control
7. Flight data logging and export

Software Architecture

1. Core Flight Stack: PX4-based firmware
2. Communication Protocol: MAVLink
3. Data Logging: ULog format
4. Firmware Update Capability: Supported via official IndiFlo toolchain

Only IndiFlo-approved firmware builds shall be deployed. Modification of PX4 core parameters without authorization may invalidate airworthiness and warranty status.



3. Battery

General Description

The aircraft utilizes an Intelligent Flight Battery system configured as:

6S5P lithium-ion configuration

Cell Type: Molicel INR-21700-M65A

The battery integrates a dedicated Battery Management System (BMS) responsible for cell balancing, safety protection, and telemetry reporting.

Technical Specification & Description

Electrical Characteristics

Cell Configuration: 6S5P

Nominal Voltage: 21.6 V

Maximum Charge Voltage: 25.2 V

Nominal Capacity: Dependent on Molicel M65A cell specification (5 cells in parallel per series group)

Maximum Continuous Discharge: As defined by pack-level current limitation

Integrated Protections:

- Over-voltage protection

- Under-voltage protection

- Over-current protection

- Over-temperature protection

- Short-circuit protection



4. Payload System

Specification for All Payloads

The IndiFlo UAS supports modular payload integration via standardized mounting and electrical interface.

Payload interface includes:

1. Mechanical quick-release mounting
2. Regulated power output
3. Data communication (MAVLink-compatible or dedicated interface)
4. Trigger signal output
5. Environmental isolation

Payload weight and CG limits must remain within approved aircraft operational envelope.

4.1 Primary Payload – ADTi Survey Camera

4.2 TBD

4.3 TBD



UAS SET-UP PROCEDURES

All setup procedures shall be performed by trained personnel in a clear, obstruction-free environment. The aircraft shall remain powered OFF during mechanical installation activities.

Airframe Preparation (Rigid Frame)

The IndiFlo airframe utilizes a **fixed, non-foldable arm configuration**. No deployment action is required prior to operation.

1. Remove aircraft from transport case.
2. Inspect all rigid arms for structural integrity.
3. Verify arm-to-center-frame fasteners are secure.
4. Confirm no cracks, delamination, or mechanical play exist.
5. Ensure landing gear is stable and undamaged.

Aircraft shall not be operated if structural integrity is compromised.

Propeller Installation (T-Motor 20” NS Series)

1. Identify CW and CCW propellers.
2. Match propeller direction with motor rotation marking.
3. Install propeller onto motor hub adapter.
4. Verify secure seating and absence of axial play

Incorrect installation may result in loss of lift and instability.



UAS SET-UP PROCEDURES

Payload Installation (ADTi Survey Camera)

1. Ensure mounting plate is clean and unobstructed.
2. Secure payload using approved fasteners.
3. Connect power and data interface cables.
4. Confirm mechanical locking and connector engagement.
5. Verify payload recognition in GCS after power-on.

Ensure payload weight and CG remain within approved operational envelope.



GCS SETUP

The IndiFlo Ground Control Station (GCS) operates on a PX4-based flight control architecture using MAVLink communication protocol.

GCS Setup Procedure

1. Power ON the GCS device.
2. Launch the IndiFlo PX4-based control software.
3. Confirm firmware version compatibility.
4. Load aircraft parameter configuration.
5. Verify telemetry radio connection.
6. Confirm:
 - IMU health
 - GPS lock status
 - Battery telemetry
 - EKF status

Verify geofence and failsafe parameters.

Confirm Return-To-Launch (RTL) altitude.

Flight shall not proceed if critical system warnings are present.



GCS Setup

GCS Connection with UAV

Power ON GCS.

Power ON UAV.

Confirm telemetry link establishment via MAVLink.

Verify live telemetry data:

- Battery voltage

- GPS satellite count

- Flight mode

- EKF health

Conduct control input verification.

Arm only after confirming system readiness.



UAV FEATURES

Flight Modes

The following flight modes are available:

1. Manual (Acro)
2. Stabilized
3. Altitude Hold
4. Position Hold
5. Mission Mode
6. Return-To-Launch (RTL)
7. Offboard Mode (if enabled)

Flight mode availability may depend on GPS and EKF status.

Return-To-Launch (RTL) Procedure

RTL may be triggered:

1. Manually via GCS
2. Automatically via failsafe
3. Upon low battery threshold

RTL Sequence:

1. Ascend to preset RTH altitude.
2. Navigate to recorded home position.
3. Descend vertically.
4. Land and disarm.

Home position must be confirmed prior to takeoff.



UAV FEATURES

Status Indicator

Aircraft LED indicators provide:

1. Arm status
2. GPS lock

Data Logging

PX4 flight controller logs:

1. IMU data
2. GPS data
3. Battery telemetry
4. Control inputs
5. EKF status

Logs are stored in ULog format and accessible via GCS.

Operators shall retain logs for regulatory compliance if required.

Altitude Hold Feature

Altitude Hold mode maintains vertical position using:

1. Barometric sensor
2. IMU
3. GPS

Vertical drift may occur in high wind or pressure instability conditions.



CALIBRATION PROCEDURES

Calibration shall be performed after firmware updates, hardware replacement, or abnormal flight behavior.

Accelerometer Calibration

1. Place aircraft on level surface.
2. Access PX4 calibration menu.
3. Follow 6-axis orientation prompts.
4. Confirm calibration success message.

Magnetometer Calibration

1. Remove metallic objects nearby.
2. Initiate compass calibration via GCS.
3. Rotate aircraft in required axes.
4. Confirm calibration completion.
5. Avoid calibration near power lines or reinforced concrete.

GPS Calibration

1. GPS does not require manual calibration; however:
2. Verify ≥ 12 satellites before arming.
3. Confirm HDOP within acceptable limits.
4. Ensure EKF reports healthy state.



CALIBRATION PROCEDURES

ESC Calibration

If required:

1. Remove propellers.
2. Enter ESC calibration mode via PX4.
3. Apply throttle per instruction.
4. Confirm calibration tone from ESCs.

8.5 Radio Calibration

1. Access radio calibration menu.
2. Move sticks through full range.
3. Verify channel mapping.
4. Confirm failsafe throttle position.



CALIBRATION PROCEDURES

ESC Calibration

If required:

1. Remove propellers.
2. Enter ESC calibration mode via PX4.
3. Apply throttle per instruction.
4. Confirm calibration tone from ESCs.

8.5 Radio Calibration

1. Access radio calibration menu.
2. Move sticks through full range.
3. Verify channel mapping.
4. Confirm failsafe throttle position.



OPERATING LIMITATIONS

Operation of the IndiFlo UAS shall be conducted strictly within the limitations defined below. Exceeding these limits may result in structural damage, loss of control, or regulatory violation.

Wind Limitations

1. Maximum Sustained Wind Speed: **6 m/s**
2. Maximum Gust: **10 m/s**

Operation above these limits may result in position instability or increased power draw.

Precipitation & Moisture

1. Light mist conditions: Permitted only if visibility maintained
2. Rainfall: Prohibited
3. Standing water immersion: Prohibited
4. High humidity (>85% RH): Not recommended

Altitude & Density Limits

1. Maximum Service Ceiling (MSL): 400 feet
2. Reduced thrust expected at high density altitude



OPERATING LIMITATIONS

Operation of the IndiFlo UAS shall be conducted strictly within the limitations defined below. Exceeding these limits may result in structural damage, loss of control, or regulatory violation.

Wind Limitations

1. Maximum Sustained Wind Speed: **6 m/s**
2. Maximum Gust: **10 m/s**

Operation above these limits may result in position instability or increased power draw.

Precipitation & Moisture

1. Standing water immersion: Prohibited
2. High humidity (>85% RH): Not recommended
3. IP rating:

Altitude & Density Limits

1. Maximum Service Ceiling (MSL): 400 feet
2. Reduced thrust expected at high density altitude

Payload & CG Limits

Maximum Takeoff Weight (MTOW): **4.5 kg**

Payload weight must remain within approved CG envelope

Unapproved payload integration is prohibited



FLIGHT MISSION PLANNING

Mission Planning Procedure

1. Verify regulatory authorization for airspace.
2. Check NOTAMs and temporary restrictions.
3. Define mission area within approved geofence.
4. Verify weather conditions within limits.
5. Upload waypoint mission via PX4 GCS.
6. Confirm:
 - Home position set
 - RTH altitude configured
 - Battery sufficient for mission duration + reserve

Mission reserve shall maintain minimum 25% battery margin.

How to Geofence

1. Geofence configuration is performed via Indi GCS.
2. Access Geofence Settings.
3. Define:
 - Horizontal boundary radius OR polygon
 - Maximum altitude limit
5. Enable geofence enforcement.
6. Select breach action:
 - RTL (default)
 - Hold position
 - Land

Save parameters and verify upload to flight controller.

Geofence shall be verified prior to arming.



EMERGENCY PROCEDURES

RTL Triggered by Battery Failure

Justification for Decision Time

Battery failsafe is triggered when:

1. Remaining capacity reaches predefined threshold (typically 20%).
2. Voltage sag below critical threshold.
3. BMS reports critical fault.
4. Decision time is calculated to allow:
5. Safe climb to RTH altitude.
6. Horizontal transit to home.
7. Reserve energy margin.

Threshold values are validated during flight testing.

Exact Aural and Visual Signature

Upon battery failsafe:

1. GCS displays “**LOW BATTERY – RTL INITIATED**”
2. Audible warning tone activated on GCS.
3. Telemetry log records event timestamp.

Behavior of UAS at RTL

Aircraft ascends to preset RTH altitude.

1. Navigates to home position.
2. Descends vertically.
3. Lands and disarms.



EMERGENCY PROCEDURES

RTL Triggered by Radio Failure

Justification for Decision Time

Radio failsafe activates when:

1. Telemetry link lost beyond timeout period.
2. RC signal lost for predefined duration (e.g., 2–5 seconds).

Timeout ensures temporary signal interference does not trigger unnecessary RTL.

Exact Aural and Visual Signature

1. GCS: “SIGNAL LOST – FAILSAFE ACTIVE”
2. Audible tone.
3. Log event recorded.

Behavior of UAS at RTL

1. Hover for brief signal recovery window.
2. If no signal restored → initiate RTL.
3. Return to home and land autonomously.

If signal restored during transit, pilot may resume control



EMERGENCY PROCEDURES

RTL Triggered by GCS Failure

Justification for Decision Time

GCS failure includes:

1. Application crash
2. Telemetry module failure
3. Ground station power loss

Failsafe relies on onboard PX4 logic independent of GCS.

Timeout ensures:

1. False triggers are minimized.
2. Controlled transition to autonomous mode.

Exact Aural and Visual Signature

1. Loss of telemetry on GCS.
2. Onboard event logged.

Behavior of UAS at RTL

1. Enter autonomous control.
2. Ascend to RTH altitude if required.
3. Navigate to home coordinates.
4. Land safely.

Autonomy continues without ground input.



EMERGENCY PROCEDURES

RTL Triggered by Breach of Geofence

Justification for Decision Time

Geofence breach occurs when:

1. Horizontal boundary exceeded.
2. Altitude limit exceeded.

Immediate response required to:

1. Maintain regulatory compliance.
2. Prevent restricted airspace entry.

No extended delay permitted.

Exact Aural and Visual Signature

1. GCS warning: “GEOFENCE BREACH”
2. Audible alert tone.
3. Mission paused.

Behavior of UAS at RTL

1. Stop further outbound motion.
2. Re-enter defined geofence boundary.
3. Initiate RTL sequence.
4. Land at home point.

Operator override only permitted within safe regulatory conditions.



WARRANTY CLAUSE

This Warranty Clause defines the scope, limitations, and conditions under which **IndiFlo Pvt. Ltd.** (“IndiFlo”) provides warranty coverage for its Unmanned Aircraft Systems (UAS), components, and associated equipment.

This warranty applies only to products purchased directly from IndiFlo or through an authorized distributor or reseller.

Limited Warranty Coverage

IndiFlo warrants that the UAS and its original components shall be free from defects in material and workmanship under normal use and service conditions for a period of:

Aircraft Frame & Structural Components: 12 months from date of delivery

Propulsion System (Motors & ESCs): 6 months or 800 flight hours (whichever occurs first)

Battery Pack (6S5P Molicel M65A): 6 months or 800 cycles (whichever occurs first)

Payload Integration Hardware: 6 months

Payload: 12 months

Warranty period shall commence from the documented delivery date to the original purchaser.



WARRANTY CLAUSE

Remedy

If a defect covered under warranty is confirmed by IndiFlo:

IndiFlo shall, at its sole discretion:

1. Repair the defective component, or
2. Replace the defective component with new or refurbished equivalent, or
3. Provide replacement parts for field installation

The repaired or replaced item shall be covered for the remainder of the original warranty period.

Warranty service shall not extend or renew the original warranty term.

Warranty Claim Procedure

To initiate a warranty claim:

Customer shall notify IndiFlo in writing within 3 days of defect discovery.

Provide:

1. Product serial number
2. Flight log data
3. Maintenance records
4. Description of fault

Obtain Return Material Authorization (RMA) prior to shipment.

Ship product in approved protective packaging.

Products returned without RMA authorization may be rejected.

Shipping costs to IndiFlo are the responsibility of the customer unless otherwise agreed.



WARRANTY CLAUSE

Warranty Conditions

Warranty coverage is valid only if the following conditions are met:

Proper Operation

- Aircraft operated within specified environmental limits.
- No operation beyond approved weight, payload, or CG limits.
- Compliance with flight manual and maintenance manual instructions.

Maintenance Compliance

- Scheduled maintenance performed per approved intervals.
- Maintenance records properly documented.
- Only IndiFlo-approved spare parts used.
- Failure to perform mandatory maintenance voids warranty coverage.

Software and Firmware Control

- Only IndiFlo-approved firmware builds deployed.
- No unauthorized PX4 parameter modifications.
- No third-party firmware flashing.
- Unauthorized software modification voids warranty.



WARRANTY EXCLUSION

Normal Wear and Tear

1. Propeller wear
2. Cosmetic damage
3. Minor surface scratches
4. Consumables

Misuse or Abuse

1. Crash damage
2. Hard landings
3. Water ingress
4. Fire or thermal event
5. Operation in prohibited airspace
6. Use in severe weather outside operational limits

Unauthorized Modification

1. Structural modification
2. Payload modification beyond approved configuration
3. Electrical rewiring
4. BMS tampering
5. Reverse engineering or disassembly



WARRANTY EXCLUSION

External Causes

1. Lightning strike
2. Electromagnetic interference damage
3. Third-party equipment integration failure
4. Use of non-approved accessories

Data Loss

IndiFlo shall not be responsible for:

1. Loss of mission data
2. Loss of mapping data
3. Corrupted flight logs
4. Business interruption



WARRANTY EXCLUSION

Limitation of Liability

To the maximum extent permitted by law:

1. IndiFlo's liability shall not exceed the original purchase price of the affected product.
2. IndiFlo shall not be liable for indirect, incidental, consequential, or punitive damages.
3. IndiFlo shall not be liable for personal injury or property damage resulting from improper operation.
4. Operator assumes full responsibility for regulatory compliance and safe use.

Void of Warranty

Warranty shall be automatically void if:

1. Serial number/UIN is removed or altered.
2. Product is disassembled without authorization.
3. Maintenance seal is broken.
4. Aircraft operated beyond rated flight envelope.
5. Mandatory firmware updates (if applicable) are ignored when required for safety.

